



SIM – Spartherm Installation Modules



Langlebig und zeitlos modern sind die Kaminanlagen in Sichtbetonoptik.

Der Werkstoff Beton ist erste Wahl, wenn es um die perfekte Kombination von Schutz, Eleganz und eine große Gestaltungsfreiheit geht.

Wie eine schützende Haut verbirgt die Betonverkleidung die Spartherm-Brennzelle in ihrem Inneren und gibt die Wärme des Holzbrandes mit angenehmen Strahlungseigenschaften langsam an den Umgebungsraum weiter. Die äußere Erscheinung der Betonverkleidung folgt den geraden Linien der modernen Architektur und wirkt in jedem Raumambiente elegant und stilvoll, ohne vom Wesentlichen abzulenken: Das behaglich wärmende Feuer.

Die angenehme Strahlungswärme wird über den Wärmebeton zeitverzögert abgegeben.

Die Fertigung von passgenauen Formteilen, die direkt auf die Spartherm-Brennzellen abgestimmt sind, ermöglicht einen absolut präzisen Aufbau mit perfektem Ergebnis in Form und Funktion.



Ihre Kreativität in Wärme verpackt

Je nach Geschmack und Bedarf sind die Betonverkleidungen auch mit geeigneten Materialien streich- und verputzbar. Sie können bei Bedarf jede Kaminanlage optional mit Erweiterungsmodulen für einen deckenbündigen Aufbau erhöhen oder die dreiseitigen Kaminanlagen mit einem eleganten Feuertisch ausstatten. Der Abgasanschluss kann nach oben oder nach hinten ausgeführt werden – bei Eckanlagen auch zur Seite.

Mit den Spartherm Installation Modules verbinden Sie die schnelle Wärme eines Warmluftofens mit den typischen Wärmespeichereigenschaften eines Kachelofens. Über eine große Scheibe mit guter Feuereinsicht ist die schnelle Wärme direkt am Körper spürbar und durch die Speichermasse auch lange als behagliche Wärmequelle verfügbar.

Der Wunsch nach einer raschen Wärmeabgabe steht bei diesen Produkten jedoch eindeutig im Vordergrund. Durch die vorhandenen Speichermassen wird eine Raumüberhitzung in Wohnräumen mit geringer Heizlast vermieden, indem die Wärme nachfolgend verzögert an den Raum abgegeben wird.

Anwendungsbeispiel für die kreative Gestaltung des Spartherm Installation Modules.



Inhalt

Seite 04 - 07	Gerade	☐
Seite 08 - 13	L-Form	☐
Seite 14 - 17	U-Form	☐
Seite 18 - 19	Variantenvielfalt	
Seite 20 - 21	Technische Daten	☉



SIM 2/2/Varia AS-4S-2

€ 20

SIM 2/2/Varia ASH-4S-2

€ 20

Wärmebeton mit moderner Oberfläche





SIM 1/3/Varia M-60h-4S GET

€ 20



SIM 2/3/Varia M-80h-4S GET

20 





SIM 2/2/Mini 2LRh-4S

20 ☺





SIM 3/3/Varia 2L-55h-4S

€ 20

Wenig Raumbedarf durch
eine kompakte Bauweise

SIM 1/3/Varia 2R-55h-4S

20 €





SIM 3/2/Varia AS-2Lh-4S

€ 20

L-Form

Qualität und Robustheit – durch passgenaue Formen

SIM 2/2/Varia AS-2Rh-4S

20 €







SIM 1/3/Arte U-70h-4S

21 €



SIM 1/3/T/Arte 3RL-60h-4S

€ 21

Viel Speichermasse – schnell aufgebaut



SIM 3/3/Arte 3RL-80h-4S

€ 21

SIM 2/3/T/Arte 3RL-100h-4S































21 



Vielfältige Variationsmöglichkeiten – Ihre Individualität, Ihr Stil

Spartherm Installation Modules	SIM Varia AS-4S-2	SIM Varia AS-4S-2 RLU	SIM Varia ASH-4S-2	SIM Varia M-60h-4S GET	SIM Varia M-80h-4S GET	SIM Varia AS-2Lh-4S	SIM Varia AS-2Rh-4S	SIM Varia 2L-55h-4S	SIM Varia 2R-55h-4S	SIM Mini 2LRh-4S
1 Modul	SIM 1/2/Varia AS-4S-2	SIM 1/2/Varia AS-4S-2 RLU	SIM 1/2/Varia ASH-4S-2	SIM 1/3/Varia M-60h-4S GET	SIM 1/3/Varia M-80h-4S GET	SIM 1/2/Varia AS-2Lh-4S	SIM 1/2/Varia AS-2Rh-4S	SIM 1/3/Varia 2L-55h-4S	SIM 1/3/Varia 2R-55h-4S	SIM 1/2/Mini 2LRh-4S
	Höhe [Gh] = 1243 mm Gewicht = 460 kg	Höhe [Gh] = 1243 mm Gewicht = 460 kg	Höhe [Gh] = 1243 mm Gewicht = 490 kg	Höhe [Gh] = 1713 mm Gewicht = 520 kg	Höhe [Gh] = 1723 mm Gewicht = 610 kg	Höhe [Gh] = 1243 mm Gewicht = 490 kg	Höhe [Gh] = 1243 mm Gewicht = 490 kg	Höhe [Gh] = 1712 mm Gewicht = 520 kg	Höhe [Gh] = 1712 mm Gewicht = 520 kg	Höhe [Gh] = 1437 mm Gewicht = 420 kg
										
2 Module	SIM 2/2/Varia AS-4S-2	SIM 2/2/Varia AS-4S-2 RLU	SIM 2/2/Varia ASH-4S-2	SIM 2/3/Varia M-60h-4S GET	SIM 2/3/Varia M-80h-4S GET	SIM 2/2/Varia AS-2Lh-4S	SIM 2/2/Varia AS-2Rh-4S	SIM 2/3/Varia 2L-55h-4S	SIM 2/3/Varia 2R-55h-4S	SIM 2/2/Mini 2LRh-4S
	Höhe [Gh] = 1508 mm Gewicht = 510 kg	Höhe [Gh] = 1508 mm Gewicht = 510 kg	Höhe [Gh] = 1508 mm Gewicht = 540 kg	Höhe [Gh] = 1918 mm Gewicht = 570 kg	Höhe [Gh] = 1928 mm Gewicht = 670 kg	Höhe [Gh] = 1508 mm Gewicht = 540 kg	Höhe [Gh] = 1508 mm Gewicht = 540 kg	Höhe [Gh] = 1917 mm Gewicht = 560 kg	Höhe [Gh] = 1917 mm Gewicht = 560 kg	Höhe [Gh] = 1642 mm Gewicht = 470 kg
										
3 Module	SIM 3/2/Varia AS-4S-2	SIM 3/2/Varia AS-4S-2 RLU	SIM 3/2/Varia ASH-4S-2	SIM 3/3/Varia M-60h-4S GET	SIM 3/3/Varia M-80h-4S GET	SIM 3/2/Varia AS-2Lh-4S	SIM 3/2/Varia AS-2Rh-4S	SIM 3/3/Varia 2L-55h-4S	SIM 3/3/Varia 2R-55h-4S	SIM 3/2/Mini 2LRh-4S
	Höhe [Gh] = 1773 mm Gewicht = 560 kg	Höhe [Gh] = 1773 mm Gewicht = 560 kg	Höhe [Gh] = 1773 mm Gewicht = 590 kg	Höhe [Gh] = 2183 mm Gewicht = 620 kg	Höhe [Gh] = 2193 mm Gewicht = 730 kg	Höhe [Gh] = 1773 mm Gewicht = 590 kg	Höhe [Gh] = 1773 mm Gewicht = 590 kg	Höhe [Gh] = 2182 mm Gewicht = 600 kg	Höhe [Gh] = 2182 mm Gewicht = 600 kg	Höhe [Gh] = 1907 mm Gewicht = 520 kg
										
Optionale Erweiterungsmodule für deckenbündigen Aufbau	✓	✓	✓	✓	✓	✓	✓	✓	✓	✓

Die Farb- und Oberflächenstruktur kann aufgrund des Betongussverfahrens variieren. Somit wird jedes Spartherm Installation Modul zum Unikat.

SIM Arte U-50h-4S		SIM Arte U-70h-4S		SIM Arte 3RL-60h-4S		SIM Arte 3RL-80h-4S		SIM Arte 3RL-100h-4S	
	optionaler Feuertisch		optionaler Feuertisch		optionaler Feuertisch		optionaler Feuertisch		optionaler Feuertisch
SIM 1/3/Arte U-50h-4S Höhe [Gh] = 1742 mm Gewicht = 730 kg	SIM 1/3/T/Arte U-50h-4S Höhe [Gh] = 1794 mm Gewicht = 760 kg	SIM 1/3/Arte U-70h-4S Höhe [Gh] = 1742 mm Gewicht = 830 kg	SIM 1/3/T/Arte U-70h-4S Höhe [Gh] = 1794 mm Gewicht = 865 kg	SIM 1/3/Arte 3RL-60h-4S Höhe [Gh] = 1768 mm Gewicht = 690 kg	SIM 1/3/T/Arte 3RL-60h-4S Höhe [Gh] = 1820 mm Gewicht = 720 kg	SIM 1/3/Arte 3RL-80h-4S Höhe [Gh] = 1768 mm Gewicht = 780 kg	SIM 1/3/T/Arte 3RL-80h-4S Höhe [Gh] = 1820 mm Gewicht = 810 kg	SIM 1/3/Arte 3RL-100h-4S Höhe [Gh] = 1768 mm Gewicht = 860 kg	SIM 1/3/T/Arte 3RL-100h-4S Höhe [Gh] = 1820 mm Gewicht = 900 kg
									
SIM 2/3/Arte U-50h-4S Höhe [Gh] = 1947 mm Gewicht = 780 kg	SIM 2/3/T/Arte U-50h-4S Höhe [Gh] = 1999 mm Gewicht = 810 kg	SIM 2/3/Arte U-70h-4S Höhe [Gh] = 1947 mm Gewicht = 885 kg	SIM 2/3/T/Arte U-70h-4S Höhe [Gh] = 1999 mm Gewicht = 920 kg	SIM 2/3/Arte 3RL-60h-4S Höhe [Gh] = 1973 mm Gewicht = 730 kg	SIM 2/3/T/Arte 3RL-60h-4S Höhe [Gh] = 2026 mm Gewicht = 760 kg	SIM 2/3/Arte 3RL-80h-4S Höhe [Gh] = 1973 mm Gewicht = 830 kg	SIM 2/3/T/Arte 3RL-80h-4S Höhe [Gh] = 2026 mm Gewicht = 860 kg	SIM 2/3/Arte 3RL-100h-4S Höhe [Gh] = 1973 mm Gewicht = 920 kg	SIM 2/3/T/Arte 3RL-100h-4S Höhe [Gh] = 2026 mm Gewicht = 960 kg
									
SIM 3/3/Arte U-50h-4S Höhe [Gh] = 2212 mm Gewicht = 830 kg	SIM 3/3/T/Arte U-50h-4S Höhe [Gh] = 2264 mm Gewicht = 860 kg	SIM 3/3/Arte U-70h-4S Höhe [Gh] = 2212 mm Gewicht = 940 kg	SIM 3/3/T/Arte U-70h-4S Höhe [Gh] = 2264 mm Gewicht = 880 kg	SIM 3/3/Arte 3RL-60h-4S Höhe [Gh] = 2238 mm Gewicht = 770 kg	SIM 3/3/T/Arte 3RL-60h-4S Höhe [Gh] = 2290 mm Gewicht = 800 kg	SIM 3/3/Arte 3RL-80h-4S Höhe [Gh] = 2238 mm Gewicht = 880 kg	SIM 3/3/T/Arte 3RL-80h-4S Höhe [Gh] = 2290 mm Gewicht = 910 kg	SIM 3/3/Arte 3RL-100h-4S Höhe [Gh] = 2238 mm Gewicht = 980 kg	SIM 3/3/T/Arte 3RL-100h-4S Höhe [Gh] = 2290 mm Gewicht = 1020 kg
									
✓	✓	✓	✓	✓	✓	✓	✓	✓	✓

Technische Daten

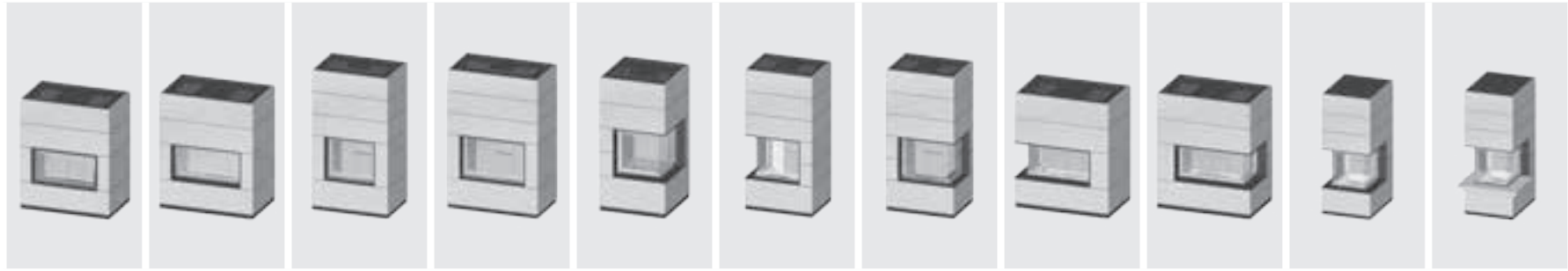
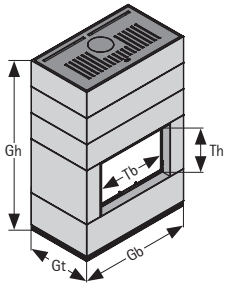

optionaler Feuertisch

Spartherm Installation Modules	SIM Varia AS-4S-2 SIM Varia AS-4S-2 RLU	SIM Varia ASH-4S-2	SIM Varia M-60h-4S GET	SIM Varia M-80h-4S GET	SIM Mini 2LRh-4S	SIM Varia 2L-55h-4S	SIM Varia 2R-55h-4S	SIM Varia AS-2Lh-4S	SIM Varia AS-2Rh-4S	SIM Arte U-50h-4S	
--------------------------------	--	--------------------	---------------------------	---------------------------	------------------	---------------------	---------------------	---------------------	---------------------	-------------------	--

Scheibenform											
Maße	Türbreite [Tb]	751 mm	730 mm	606 mm	802 mm	465/465 mm	583/391 mm	583/391 mm	730/358 mm	730/358 mm	499/501/499 mm
	Türhöhe [Th]	377 mm	370 mm	514 mm	520 mm	500 mm	510 mm	510 mm	370 mm	370 mm	544 mm
	Gesamtbreite [Gb]	1022 mm	1022 mm	938 mm	1135 mm	719 mm	834 mm	834 mm	1022 mm	1022 mm	720 mm 880 mm
	Gesamttiefe [Gt]	650 mm	650 mm	650 mm	650 mm	719 mm	638 mm	638 mm	650 mm	650 mm	900 mm 980 mm
	Rauchrohr ø	180 mm	180 mm	180 mm	180 mm	180 mm	180 mm	180 mm	200 mm	200 mm	200 mm
Leistungen	NW-Leistung	7,0 kW	7,0 kW	8,0 kW	9,0 kW	7,0 kW	7,0 kW	7,0 kW	7,0 kW	7,0 kW	9,0 kW
	Wärmeleistungsbereich	4,9 - 9,1 kW	4,9 - 9,1 kW	5,6 - 10,4 kW	6,3 - 11,7 kW	4,9 - 9,1 kW	4,9 - 9,1 kW	4,9 - 9,1 kW	4,9 - 9,1 kW	4,9 - 9,1 kW	6,3 - 11,7 kW
	Wirkungsgrad	> 80 %	> 80 %	80 %	> 80 %	80 %	> 80 %	> 80 %	> 80 %	> 80 %	80 %
	Abgasmassenstrom	7,0 g/s	7,0 g/s	7,3 g/s	7,0 g/s	6,2 g/s	6,1 g/s	6,1 g/s	6,6 g/s	6,6 g/s	8,6 g/s
	Abgastemperatur am Gerätstutzen	275 °C	275 °C	311 °C	279 °C	343 °C	325 °C	325 °C	311 °C	311 °C	310 °C
	min. Förderdruck am Gerätstutzen	12 Pa	12 Pa	12 Pa	12 Pa	12 Pa	12 Pa	12 Pa	12 Pa	12 Pa	12 Pa
	BlmSchV 1.Stufe 2.Stufe	✓ ✓	✓ ✓	✓ ✓	✓ ✓	✓ ✓	✓ ✓	✓ ✓	✓ ✓	✓ ✓	✓ ✓
15a BVG (Österreich)	✓	✓	✓	✓	✓	✓	✓	✓	✓	✓	
als Kaminofen geprüft nach**	EN 13240	EN 13240	EN 13240	EN 13240	-	-	-	-	-	EN 13240	
Info	Türfunktion	klappbar	hochschiebbar	hochschiebbar	hochschiebbar	hochschiebbar	hochschiebbar	hochschiebbar	hochschiebbar	hochschiebbar	hochschiebbar
	Gewicht der Brennzelle	171 kg	212 kg	205 kg	250 kg	160 kg	240 kg	240 kg	212 kg	212 kg	351 kg

Die Abbildungen zeigen die Modelle mit einem Unterbaumodul.
Angaben zur Gesamthöhe und zum Gewicht der jeweiligen Ausführungen entnehmen Sie bitte der Übersicht auf der Seite 18/19.

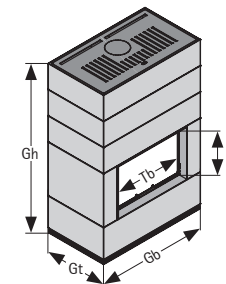

optionaler Feuertisch optionaler Feuertisch optionaler Feuertisch optionaler Feuertisch Spartherm Installation Modules

SIM Arte U-70h-4S SIM Arte 3RL-60h-4S SIM Arte 3RL-80h-4S SIM Arte 3RL-100h-4S



712/501/712 mm		370/600/370 mm		400/800/400 mm		450/1000/450 mm		Türbreite [Tb]
544 mm		570 mm		570 mm		570 mm		Türhöhe [Th]
720 mm	880 mm	820 mm	980 mm	1020 mm	1180 mm	1220 mm	1380 mm	Gesamtbreite [Gb]
1300 mm	1380 mm	795 mm	875 mm	835 mm	915 mm	875 mm	955 mm	Gesamttiefe [Gt]
200 mm		200 mm		200 mm		200 mm		Rauchrohr ø

Maße

11,0 kW	7,5 kW	9,0 kW	11,0 kW	NW-Leistung
7,7 - 14,3 kW	5,3 - 9,8 kW	6,3 - 11,7 kW	7,7 - 14,3 kW	Wärmeleistungsbereich
> 78 %	> 80 %	> 80 %	> 78 %	Wirkungsgrad
11,3 g/s	7,0 g/s	7,3 g/s	10,3 g/s	Abgasmassenstrom
310 °C	310 °C	335 °C	360 °C	Abgastemperatur am Gerätetutzen
12 Pa	12 Pa	12 Pa	12 Pa	min. Förderdruck am Gerätetutzen
✓ ✓	✓ ✓	✓ ✓	✓ ✓	BlmSchV 1.Stufe 2.Stufe
✓	✓	✓	✓	15a BVG (Österreich)
EN 13240	EN 13240	EN 13240	EN 13240	als Kaminofen geprüft nach**

Leistungen

hochschiebbar	hochschiebbar	hochschiebbar	hochschiebbar	Türfunktion
375 kg	321 kg	351 kg	371 kg	Gewicht der Brennzone

Info

Trockengewichte der SIM-Verkleidungselemente

Gerät	C-Element (kg)	Ringelement (kg)
Varia AS-4S-2 / RLU	26	41
Varia ASH-4S-2	26	41
Varia AS-2Lh-4S	42	41
Varia AS-2Rh-4S	42	41

Gerät	C-Element (kg)	Ringelement (kg)		Feuertisch (kg)
		klein	hoch	
Varia M-60h-4S GET	33	42	50	-
Varia M-80h-4S GET	36	46	57	-
Mini 2LRh-4S	20	32	42	-
Varia 2L-55h-4S	23	38	48	-
Varia 2R-55h-4S	23	38	48	-
Arte U-50h-4S	18	42	52	30
Arte U-70h-4S	23	54	65	36
Arte 3RL-60h-4S	20	42	50	27
Arte 3RL-80h-4S	23	48	58	32
Arte 3RL-100h-4S	26	55	67	35



**** Besonderheit der 1- und 3-seitigen SIM Anlagen:**



Diese Geräte wurden nach EN 13240 (als Kaminöfen) geprüft und dürfen ohne weitere Maßnahmen wie z.B. Dämmung/Vormauerung oder ähnlichem vor brennbare oder zu schützende Wände verbaut werden!

Erleben Sie ...



- ... vielfältige Übersicht sämtlicher Modellvarianten
- ... die nächste Generation – LINEAR 2
- ... Kachel- und Speicheröfen
- ... Sonderanfertigungen
- ... Wasser- und Wärmespeichertechnik
- ... Zubehör – Für effizientes Heizen



Brennzellen – und vieles mehr

SPARTHHERM – THE FIRE COMPANY



Ihr Fachhändler:



Spartherm Feuerungstechnik GmbH

Maschweg 38 · D-49324 Melle · Tel. +49 5422/94 41-0 · Fax +49 5422/94 41-14
info@spartherm.com · www.spartherm.com

Service-Hotline 0180 594 41 94

14 Cent/Minute inkl. MwSt. aus den deutschen Festnetzen,
max. 42 Cent/Minute inkl. MwSt. aus den deutschen Mobilfunknetzen

